

ACCESSORIES		DEG	ELEV	DOME
MK	SIZE	DESCRIPTION		

- NOTES:
- 16" MANWAY W/ LEVER LOCKING COVER
 - OPTIONAL 21" THREADED.
 - 7" X 9" LOWER FLAT SPOT (4 PLACES)
 - 14" X 13" DOME FLAT SPOT (3 PLACES)
 - 28" X 43" MANWAY FLAT
 - LIFTING LUG ASSEMBLY (4 PLACES)

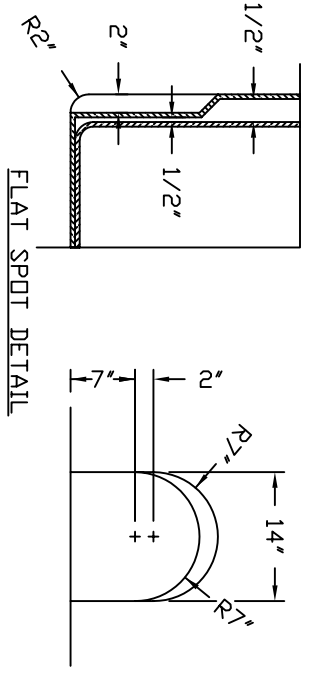
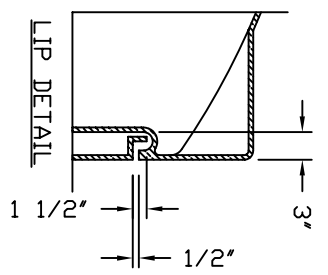

REV	A	CORRECTED DOME FLAT DIMENSIONS	10/10/12 MG
REV		REVISION DESCRIPTION	REV DATE

		300 N TAYLOR ROAD GARRETT, IN 46738 PHONE: (260) 357-3181 FAX: (260) 357-3738		CUSTOMER APPROVAL _____ DATE: _____	
PRIMARY VESSEL RESIN USED: POLYETHYLENE TANK WEIGHT: - LBS. TANK COLOR: -	SPECIFIC GRAVITY: - SP.G. MAX: - TANK WEIGHT: - LBS.	SECONDARY VESSEL RESIN USED: POLYETHYLENE TANK WEIGHT: - TANK COLOR: -	SPECIFIC GRAVITY: - SP.G. MAX: - TANK WEIGHT: - LBS.	OVERALL TANK WEIGHT: - LBS.	DRAWN BY: D. MYERS DWG NUMBER: IMT 1550 DATE: 5/77/03
TITLE: IMT 1550 GAL. DOUBLE WALL STORAGE TANK ASSMANN CORPORATION			ALL DIMENSIONS ARE IN INCHES AND ARE ±3%		