

ACCESSORIES

MK	QTY	SIZE	DESCRIPTION
A	1	-	PVC/ SCH. 80 BULKHEAD W/ EPDM (STANDARD)
B	1	-	POLYETHYLENE PIPE SUPPORT BRACKET. (STANDARD) WITH S/S BOLTS, EPDM ENCAPSULATED HEADS & EPDM GASKET
C	1	-	PVC/ SCH. 80 PIPE (STANDARD)

MATERIALS:

BULKHEAD FITTING:

PVC CPVC POLYPROPYLENE PVDF (OPTIONAL)

PIPING:

PVC CPVC POLYPROPYLENE PVDF (OPTIONAL)

DONKER BOLTS:

SS-EPDM SS-VITON TT-EPDM TT-VITON  
HST-EPDM HST-VITON

GASKET:

E.P.D.M. VITON XLPE BUINA GORTEX (OPTIONAL)

SIZES AVAILABLE:

1' 1 1/2' 2' 3'

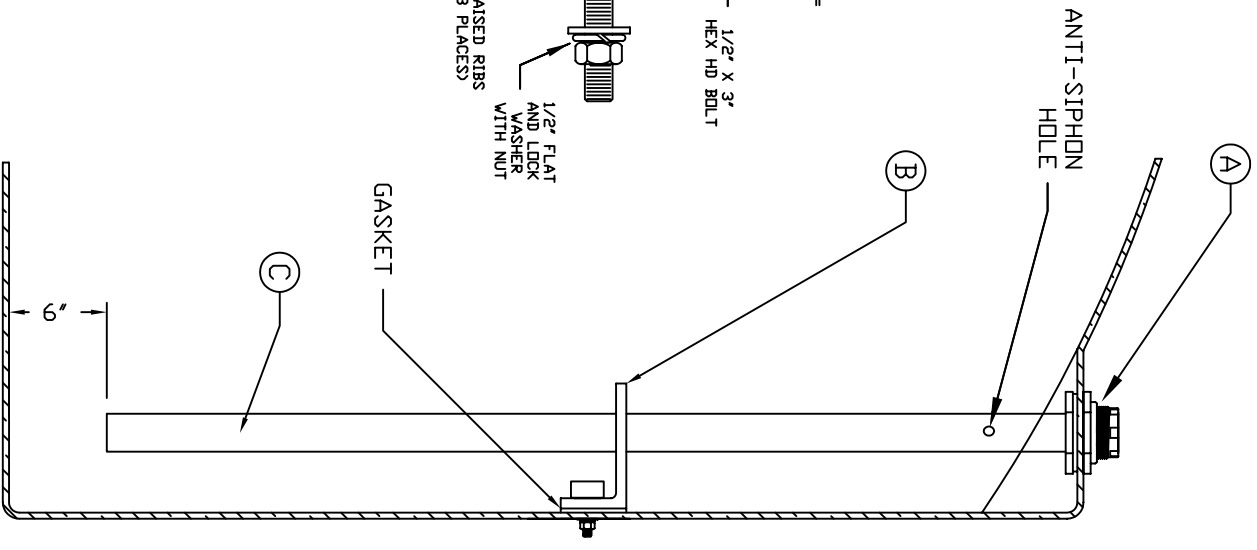

DONKER BOLT DETAIL

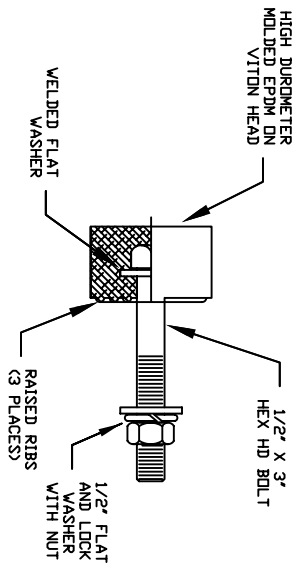

REV	A	UPDATED TITLE BLOCK	4/27/09 MG
REV		REVISION DESCRIPTION	REV DATE
TITLE		SALES ORDER	
DROP TUBE ASSEMBLY WITH BULKHEAD FITTING		DRAWN BY: D. CRAGER	
CORPORATION OF AMERICA		DATE: 9/18/96	
300 N TAYLOR ROAD		DWG NUMBER: DT-BH A	
GARRETT, IN 46738		REV	
PHONE: (260) 357-3181		A	
FAX: (260) 357-3738			