

MATERIAL LIST

MR NO	DESCRIPTION
A 1	TOP RING: 3" O.D. X 1/4" PIPE ROLLED TO 137" I.D.
B 1	BOTTOM RING: 3" O.D. X 1/4" PIPE ROLLED TO 30" I.D.
C 24	SUPPORT BRACES: 3" X 3" X 1/4" BOX TUBE CUT TO 53" LONG WITH 1 1/2" RADIUS CUT ON EACH END
D 6	PAN: FORMED IN (6 PCS.) FROM 3/16" SHEET STEEL WITH A TOP RADIUS OF 71 1/2" AND A BOTTOM RADIUS OF 7"
E 12	TOP LEG SUPPORT: 3" X 3" X 1/4" ANGLE IRON 15" LONG ROLLED TO A 71 1/2" INSIDE RADIUS
F 12	BOTTOM FOOT PAD: 3" X 3" X 1/4" ANGLE IRON 22" LONG WITH (2ea.) 5/8" HOLES DRILLED AND CENTERED 6" IN FROM EACH END
G 24	LEG: 2 1/2" X 2 1/2" X 5/16" BOX TUBE 56" 3/4" LONG ANGLE SUPPORT BRACES: 2 1/2" X 2 1/2" X 3/16" TUBE 49" LONG EACH END TO BE CAPPED WITH 1/4" FLAT STOCK AND 1 ea. 2 1/2" X 3" X 1/4" FLAT STOCK WELDED TO EACH END & 9/16" HOLE DRILLED 1" IN FROM END OF EACH EAR
H 12	

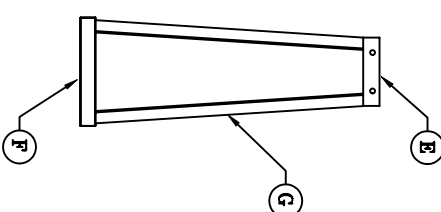
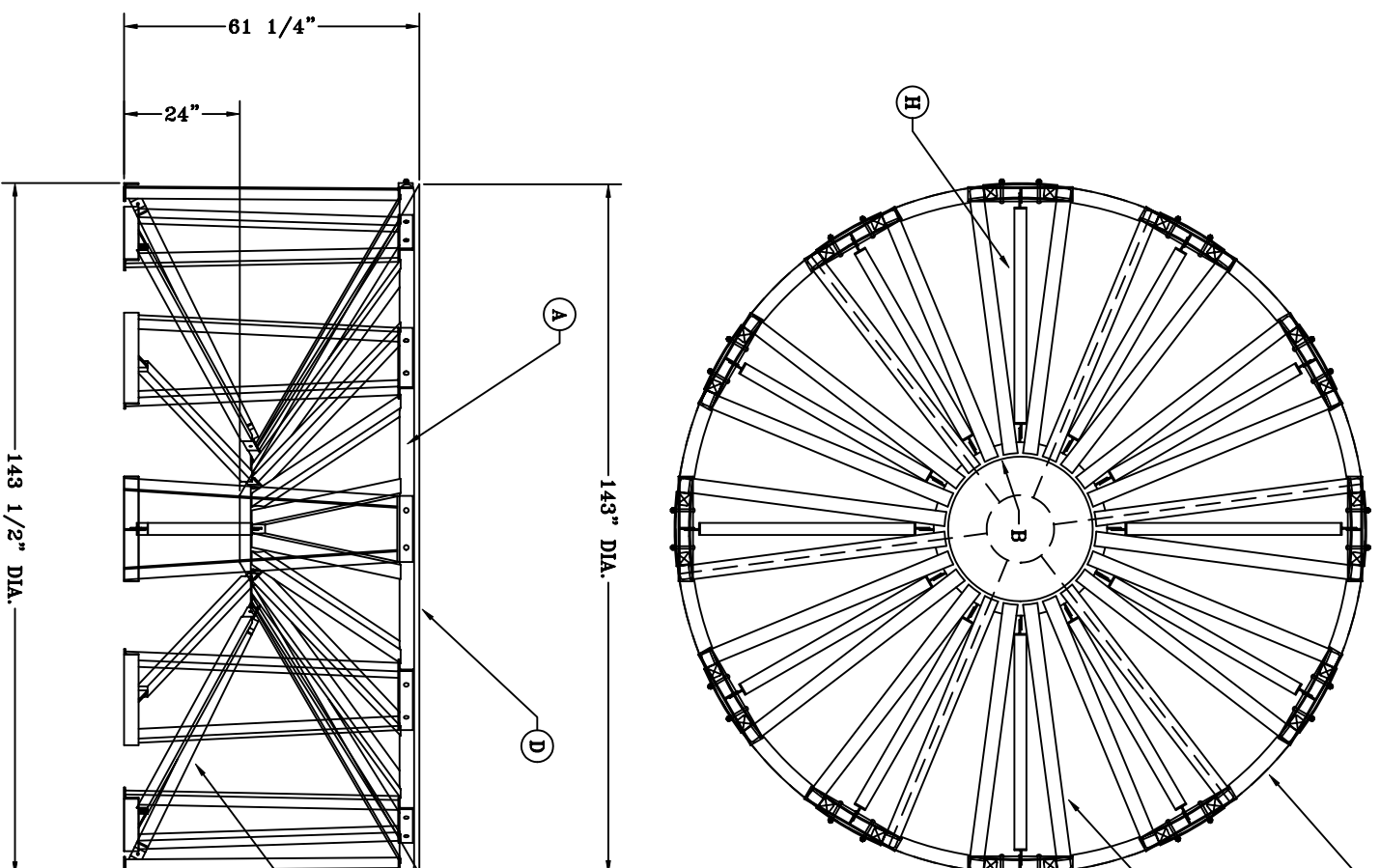

REV	DATE	DESCRIPTION	BY
1	11/30/93	NONE	
ICS 143" DIA. STAND FOR 6000 AND 8000 gal. CONICAL BOTTOM TANKS ASSMAN CORPORATION OF AMERICA IN CHARGE D. CRAIGER ICS 143			