

ACCESSORIES					
MK	SIZE	DESCRIPTION	DEG	ELEV	DOME
A	11	THREADED ACCESS OPENING WITH GASKET (MANWAY)	0	-	X

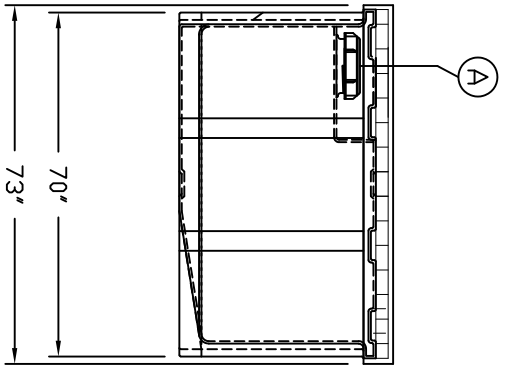
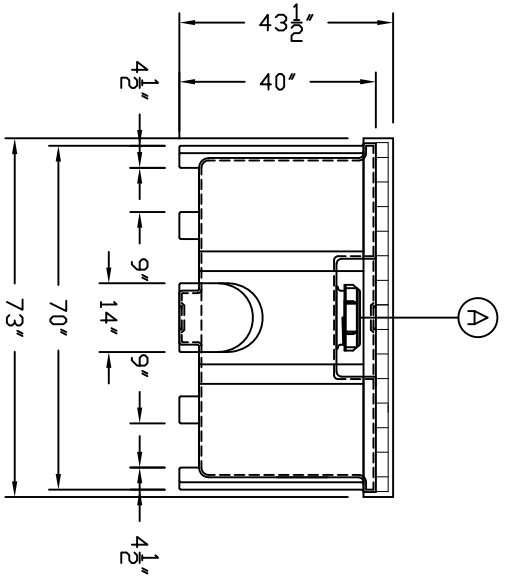
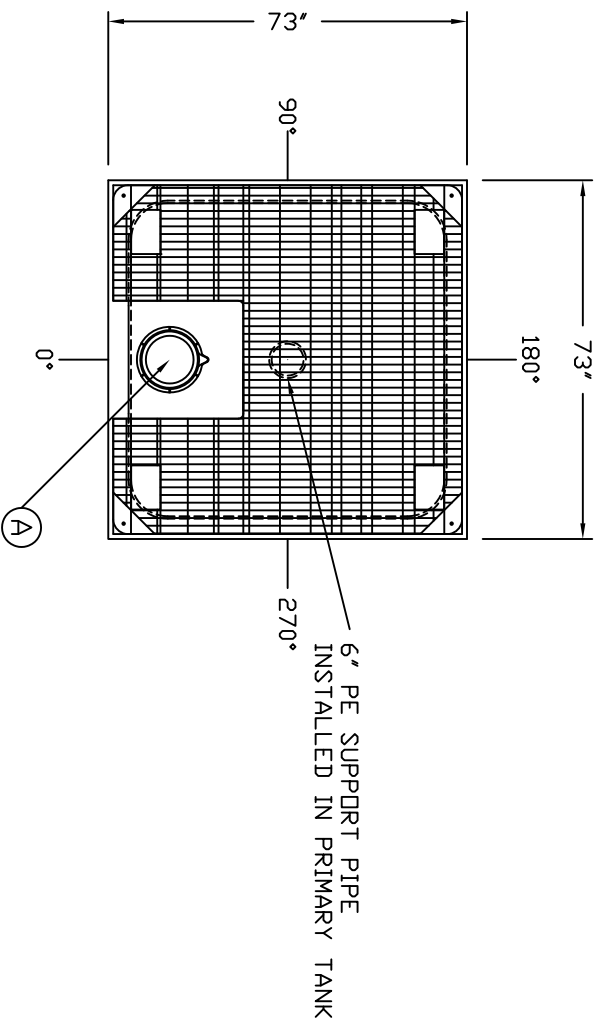

NOTES:  
 1 MAXIMUM LOAD CAPACITY FOR THIS UNIT IS 4500 LBS. @ 3 1/2" HOUR INCREMENTS  
 2 ASSEMBLY IS DESIGNED FOR INDOOR USE ONLY

A	REMOVED TANK FITTINGS	10/29/14	JL
REV	REVISION DESCRIPTION	REV	DATE

	300 N TAYLOR ROAD GARRETT IN 46738 PHONE: (260) 357-3181 FAX: (260) 357-9728	CUSTOMER APPROVAL	667 LBS.
	PRIMARY VESSEL SPECIFIC GRAVITY 1.9 SP.G. MAX TANK WEIGHT 307 LBS. TANK COLOR NATURAL	SECONDARY VESSEL SPECIFIC GRAVITY - SP.G. MAX TANK WEIGHT 535 LBS. TANK COLOR NATURAL	
POLYETHYLENE RESIN USED: POLYETHYLENE			
TITLE: BC 450 GAL. DOUBLEWALL UNIVERSAL BASE CONTAINER			
ALL DIMENSIONS ARE IN INCHES AND ARE ±3%		DRAWN BY: S. R. WILLIAMS DWG NUMBER: BC450-2	DRAWN DATE: 1/6/09 REV: