

TOP VIEW

NOTES:
 1 LADDER BRACKET CONSTRUCTED FROM 1/4" x 4"
 FLAT PLATE.
 2 BRACKET COATED WITH BLACK EPOXY PAINT.

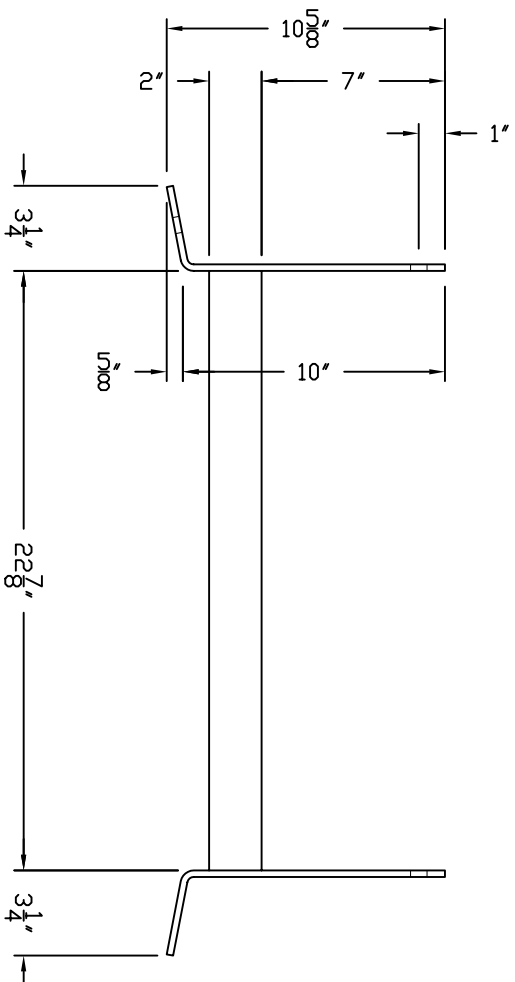

FRONT VIEW

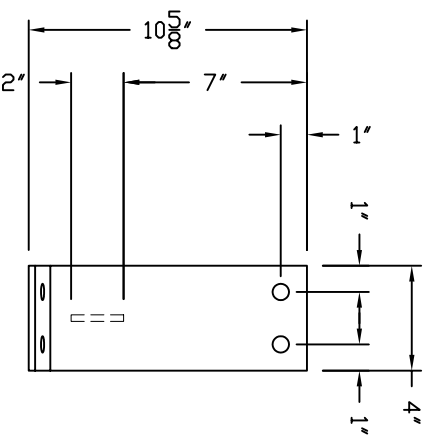

END VIEW

REV	REVISION DESCRIPTION	REV DATE
	 300 N TAYLOR ROAD GARRETT, IN 46738 PHONE: (260) 357-3181 FAX: (260) 357-3738	
	TITLE: MILD STEEL EPOXY COATED LADDER BRACKET CHEMICAL PROCESS	
	DRAWN BY: S RYAN LISON CHECKED DATE: 2/21/08 DWG NUMBER: MS-LB-	
		REV