

Lifting Instructions for Polyethylene Tanks

A WHITE PAPER FROM ASSMANN

Assmann rotationally molded tanks are by far the toughest polyethylene tanks offered to the industrial market. However, the fittings and tanks are susceptible to damage if improperly handled.

Whenever possible, use a crane or other suitable lifting devices to remove the tanks from the truck. Because the stability of the tanks can be affected by wind, the party responsible for off-loading the tank shall secure the tank to keep total control of the vessel while handling.

Consult Assmann Corporation's Tank Installation and Use Guidelines for complete installation instructions.

See fig#1 and #2 for suggestions on how to handle the tanks without lifting lugs when off loaded.

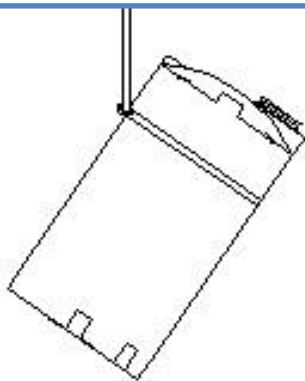

Figure #1

Using an appropriate lifting device make a choker collar and grasp the top one-third of the tank. While maintaining full control gently raise the storage tank, lift tank to safe height and move to installation point. Upright tank by setting tank on base and moving lifting device in opposite direction of lean.

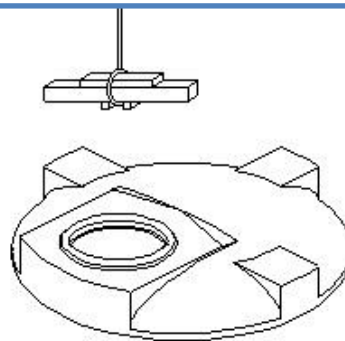

Figure #2

Using an appropriate lifting device lower a spreader bar, tee bar or 4" x 4" wooden beam through the top of the manway. (*Parts over 400 Lbs. may require a steel beam in place of the wooden beam*). While maintaining full control gently raise the storage tank, lift tank to safe height and move to installation point. Upright tank by setting tank on base and moving lifting device in opposite direction of lean.

See figure #3 and #4 for suggestions on how to handle the tanks with lifting lugs when off loaded.

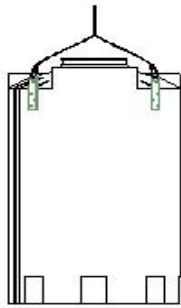
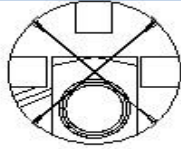
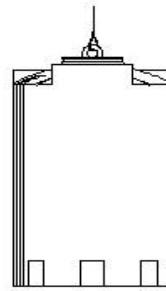
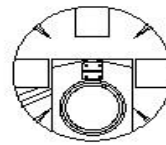

Figure #3

Using an appropriate lifting device lace cable through side mount lifting lugs. Carefully lift tank taking care not to allow tank to roll over installed nozzles. While maintaining control, lift tank to safe height and move to installation point. Disperse load evenly over all lugs using a spreader bar or other suitable means.



Figure#4

Using an appropriate lifting device lace cable through center mount lifting lug or lugs. Carefully lift tank taking care not to allow tank to roll over installed nozzles. While maintaining control, lift tank to safe height and move to installation point. Disperse load evenly over all lugs using a spreader bar or other suitable means.

See figure #5 and #6 for suggestions on how to handle the tanks that arrive placed on their side with or without lifting lugs.

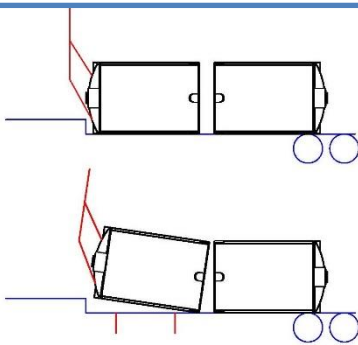

Figure #5

Using an appropriate lifting device attached rigging to top of the storage tank. Next block the tank base to prevent rolling. While maintaining control lift top of tank to allow room to place cradle strapping beneath tank. Then lower tank and re-attach rigging to cradle strapping. Carefully lift tank and place on flat surface. Re-block tank to prevent rolling. Re-attach rigging to top lifting lugs. Slowly lift tank from top lugs to upright tank. Lift tank to safe height and move to installation point.

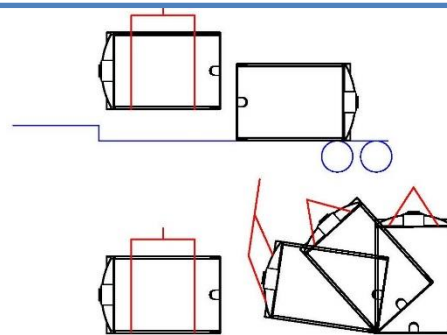

Figure #6